

BH-60 Fixed Gas Detector

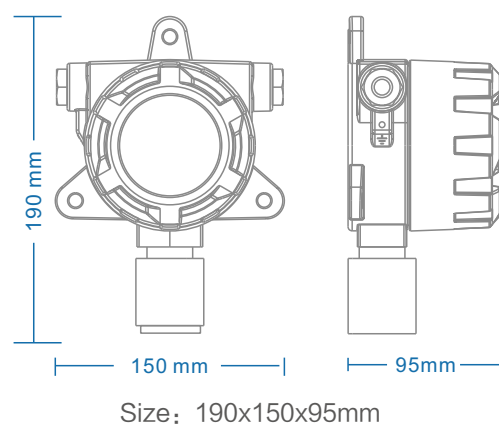

Technical Parameters

Explosion-proof:	Exd II C T6 Gb	Response Time:	≤30S
Volts:	DC24V ± 10%	Working Temperature:	-20°C ~ 50°C
Output current:	4-20mA	Humidity:	10-95%RH(No dew)
Relay:	Free contact full loadpower 1KW		
Signal Output:	Three-wire 4-20mA /Four-wire Rs485		

BH-60 Fixed Gas Detector

BH-60 fixed gas detector is a new type of gas detector developed and produced in combination with the company's many years of experience in gas detection. It is used to detect the concentration of flammable gases or other toxic and harmful gases in the air. When the concentration reaches or exceeds the preset alarm value. The controller will give an audible and visual alarm, promptly remind people take safety measures to prevent the occurrence of explosions and poisoning incidents, thus ensuring the safety of life and property.

This product has the advantages of stable signal, high precision, rapid response, long life, short polarization time, etc. It adopts industrial grade sensor, the instrument casing adopts explosion-proof explosion-proof structure design, 4-20mA standard signal or directly enters DOS system, which can be widely used in the metallurgical, petroleum, chemical, municipal and other industries, it is at the leading level of similar products in China.



Sketch Map

